

Slim MCBs Ex9B40J, 6 kA



- Slim Miniature Circuit Breakers according to IEC/EN 60898-1
- Rated short circuit breaking capacity 6 kA
- 1 up to 4-pole versions
- Tripping characteristics B, C
- Rated current up to 40 A
- Rated operational voltage 230/400 V AC,
- Wide range of accessories

Slim miniature circuit breakers Ex9B40J are devices suitable for domestic as well as commercial applications. The 3/4 module width - 13.5mm width per pole instead of 18mm of regular devices, makes this series the best option for space demanding installations.

It has been preserved the internal structure of the regular Ex9B product family in the slim miniature circuit breakers, making the Ex9B40J full compatible with the accessories of the regular circuit breakers: shunt trip releases, undervoltage and overvoltage releases, auxiliary contacts and alarm contacts. It can be used up to three units of auxiliary or alarm contacts plus up to two release units.

Type Key

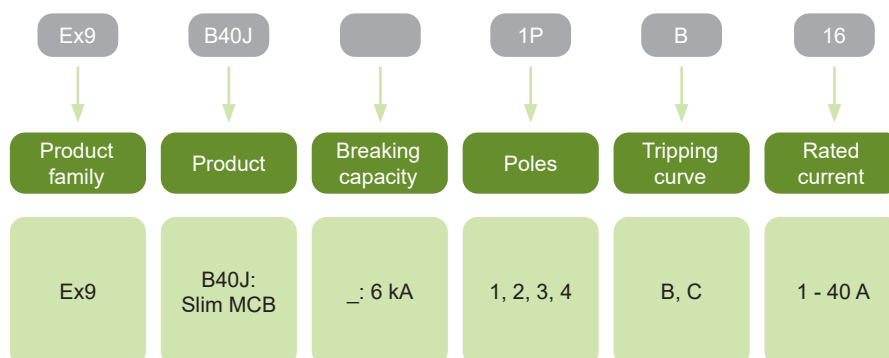

Certification marks



Slim MCBs Ex9B40J, 6 kA

Accessories

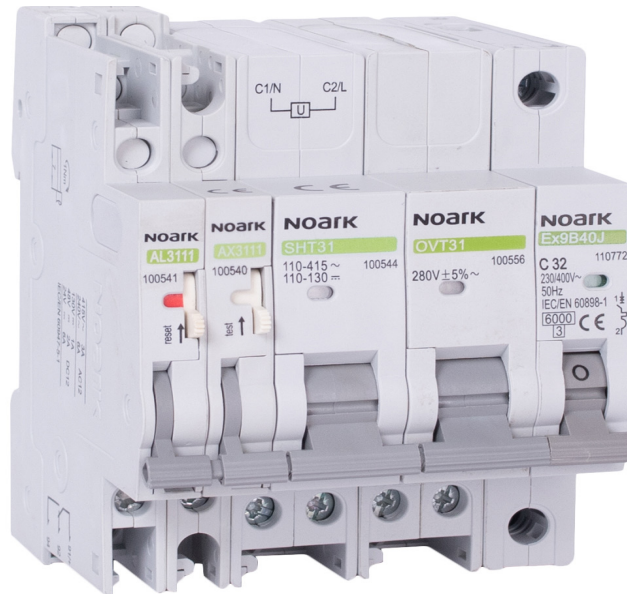

Auxiliary or signal contacts
AX, AL, AXL
Up to 3 units

Voltage or trip releases
SHT, UVT, OVT
Up to 2 units

MCB
Ex9B40J
1, 2, 3, 4-pole

Auxiliary contacts AX3111, AX3122

Alarm contact AL3111

Auxiliary and alarm contact AXL31

Shunt trip releases SHT31, SHT3111

Undervoltage releases UVT31, UVT3101, UVT3110

Overvoltage release OVT31

Slim MCBs Ex9B40J, 6 kA

B-Characteristic, 1-pole



Rated current	Poles	Char.	Article No.	Type	Packing
1 A	1	B	110719	Ex9B40J 1P B1	1/16/192
2 A	1	B	110720	Ex9B40J 1P B2	1/16/192
3 A	1	B	110721	Ex9B40J 1P B3	1/16/192
4 A	1	B	110722	Ex9B40J 1P B4	1/16/192
6 A	1	B	110723	Ex9B40J 1P B6	1/16/192
10 A	1	B	110724	Ex9B40J 1P B10	1/16/192
16 A	1	B	110725	Ex9B40J 1P B16	1/16/192
20 A	1	B	110726	Ex9B40J 1P B20	1/16/192
25 A	1	B	110727	Ex9B40J 1P B25	1/16/192
32 A	1	B	110728	Ex9B40J 1P B32	1/16/192
40 A	1	B	110729	Ex9B40J 1P B40	1/16/192

B-Characteristic, 2-pole



Rated current	Poles	Char.	Article No.	Type	Packing
1 A	2	B	110730	Ex9B40J 2P B1	1/8/96
2 A	2	B	110731	Ex9B40J 2P B2	1/8/96
3 A	2	B	110732	Ex9B40J 2P B3	1/8/96
4 A	2	B	110733	Ex9B40J 2P B4	1/8/96
6 A	2	B	110734	Ex9B40J 2P B6	1/8/96
10 A	2	B	110735	Ex9B40J 2P B10	1/8/96
16 A	2	B	110736	Ex9B40J 2P B16	1/8/96
20 A	2	B	110737	Ex9B40J 2P B20	1/8/96
25 A	2	B	110738	Ex9B40J 2P B25	1/8/96
32 A	2	B	110739	Ex9B40J 2P B32	1/8/96
40 A	2	B	110740	Ex9B40J 2P B40	1/8/96

B-Characteristic, 3-pole



Rated current	Poles	Char.	Article No.	Type	Packing
1 A	3	B	110741	Ex9B40J 3P B1	1/5/60
2 A	3	B	110742	Ex9B40J 3P B2	1/5/60
3 A	3	B	110743	Ex9B40J 3P B3	1/5/60
4 A	3	B	110744	Ex9B40J 3P B4	1/5/60
6 A	3	B	110745	Ex9B40J 3P B6	1/5/60
10 A	3	B	110746	Ex9B40J 3P B10	1/5/60
16 A	3	B	110747	Ex9B40J 3P B16	1/5/60
20 A	3	B	110748	Ex9B40J 3P B20	1/5/60
25 A	3	B	110749	Ex9B40J 3P B25	1/5/60
32 A	3	B	110750	Ex9B40J 3P B32	1/5/60
40 A	3	B	110751	Ex9B40J 3P B40	1/5/60

B-Characteristic, 4-pole



Rated current	Poles	Char.	Article No.	Type	Packing
1 A	4	B	110752	Ex9B40J 4P B1	1/4/48
2 A	4	B	110753	Ex9B40J 4P B2	1/4/48
3 A	4	B	110754	Ex9B40J 4P B3	1/4/48
4 A	4	B	110755	Ex9B40J 4P B4	1/4/48
6 A	4	B	110756	Ex9B40J 4P B6	1/4/48
10 A	4	B	110757	Ex9B40J 4P B10	1/4/48
16 A	4	B	110758	Ex9B40J 4P B16	1/4/48
20 A	4	B	110759	Ex9B40J 4P B20	1/4/48
25 A	4	B	110760	Ex9B40J 4P B20	1/4/48
32 A	4	B	110761	Ex9B40J 4P B32	1/4/48
40 A	4	B	110762	Ex9B40J 4P B40	1/4/48

Slim MCBs Ex9B40J, 6 kA

C-Characteristic, 1-pole



Rated current	Poles	Char.	Article No.	Type	Packing
1 A	1	C	110763	Ex9B40J 1P C1	1/16/192
2 A	1	C	110764	Ex9B40J 1P C2	1/16/192
3 A	1	C	110765	Ex9B40J 1P C3	1/16/192
4 A	1	C	110766	Ex9B40J 1P C4	1/16/192
6 A	1	C	110767	Ex9B40J 1P C6	1/16/192
10 A	1	C	110768	Ex9B40J 1P C10	1/16/192
16 A	1	C	110769	Ex9B40J 1P C16	1/16/192
20 A	1	C	110770	Ex9B40J 1P C20	1/16/192
25 A	1	C	110771	Ex9B40J 1P C20	1/16/192
32 A	1	C	110772	Ex9B40J 1P C32	1/16/192
40 A	1	C	110773	Ex9B40J 1P C40	1/16/192

C-Characteristic, 2-pole



Rated current	Poles	Char.	Article No.	Type	Packing
1 A	2	C	110774	Ex9B40J 2P C1	1/8/96
2 A	2	C	110775	Ex9B40J 2P C2	1/8/96
3 A	2	C	110776	Ex9B40J 2P C3	1/8/96
4 A	2	C	110777	Ex9B40J 2P C4	1/8/96
6 A	2	C	110778	Ex9B40J 2P C6	1/8/96
10 A	2	C	110779	Ex9B40J 2P C10	1/8/96
16 A	2	C	110780	Ex9B40J 2P C16	1/8/96
20 A	2	C	110781	Ex9B40J 2P C20	1/8/96
25 A	2	C	110782	Ex9B40J 2P C25	1/8/96
32 A	2	C	110783	Ex9B40J 2P C32	1/8/96
40 A	2	C	110784	Ex9B40J 2P C40	1/8/96

C-Characteristic, 3-pole



Rated current	Poles	Char.	Article No.	Type	Packing
1 A	3	C	110785	Ex9B40J 3P C1	1/5/60
2 A	3	C	110786	Ex9B40J 3P C2	1/5/60
3 A	3	C	110787	Ex9B40J 3P C3	1/5/60
4 A	3	C	110788	Ex9B40J 3P C4	1/5/60
6 A	3	C	110789	Ex9B40J 3P C6	1/5/60
10 A	3	C	110790	Ex9B40J 3P C10	1/5/60
16 A	3	C	110791	Ex9B40J 3P C16	1/5/60
20 A	3	C	110792	Ex9B40J 3P C20	1/5/60
25 A	3	C	110793	Ex9B40J 3P C25	1/5/60
32 A	3	C	110794	Ex9B40J 3P C32	1/5/60
40 A	3	C	110795	Ex9B40J 3P C40	1/5/60

C-Characteristic, 4-pole



Rated current	Poles	Char.	Article No.	Type	Packing
1 A	4	C	110796	Ex9B40J 4P C1	1/4/48
2 A	4	C	110797	Ex9B40J 4P C2	1/4/48
3 A	4	C	110798	Ex9B40J 4P C3	1/4/48
4 A	4	C	110799	Ex9B40J 4P C4	1/4/48
6 A	4	C	110800	Ex9B40J 4P C6	1/4/48
10 A	4	C	110801	Ex9B40J 4P C10	1/4/48
16 A	4	C	110802	Ex9B40J 4P C16	1/4/48
20 A	4	C	110803	Ex9B40J 4P C20	1/4/48
25 A	4	C	110804	Ex9B40J 4P C25	1/4/48
32 A	4	C	110805	Ex9B40J 4P C32	1/4/48
40 A	4	C	110806	Ex9B40J 4P C40	1/4/48

Technical Data Ex9B40J

Slim Miniature Circuit Breakers, 6 kA

General parameters

Normal limiting of short circuit current		
Suitable for household as well as commercial applications		
Accessories		
Auxiliary contacts	AX3111, AX3122	100540, 100542
Alarm contact	AL3111	100541
Auxiliary and alarm contact	AXL31	100543
Shunt trip releases	SHT31, SHT3111	100544-100546, 100547-100549
Undervoltage releases	UVT31, UVT3101, UVT3110	100550-100551, 100552-100553, 100554-100555
Oversvoltage release	OVT31 280V AC±5%	100556
Max. number of installed accessories is 3 pcs of one contact units (AX3111, AL3111) or 2 pcs of two contact units (AX3122, AXL31) and 2 pcs of releases (SHT31, UVT31, OVT31)		

Electrical parameters

Tested according to	IEC / EN 60898-1
Rated op. voltage U_e	230/400 V AC
Rated frequency	50 Hz
Rated breaking capacity I_{cn}	6 kA
Rated current	1 — 40 A
Tripping characteristics	B, C
Rated impulse withstand voltage U_{imp}	4 kV
Rated insulation voltage U_i	690 V AC
Mechanical service life	15 000 operation cycles
Electrical service life	10 000 operation cycles
Selectivity class	3
Line voltage connection	arbitrary above or below

Mechanical parameters

Device width	13.5 mm (per pole)
Device height	83 mm (89 mm including rail clip)
Frame size	45 mm
Mounting	easy fastening onto 35 mm device rail (DIN)
Degree of protection	IP20
Terminals	open mouthed
Terminal capacity	1 — 16 mm ²
Fastening torque of terminals	1.5 Nm
Ambient temperature	-25 — +70 °C
Altitude	≤ 2000 m
Relative humidity	≤ 95 %
Resistance to humidity and heat	class 2
Pollution degree	2
Installation class	III
Weight	0.086 kg (per pole)

Technical Data Ex9B40J

Slim Miniature Circuit Breakers, 6 kA

Dimensions

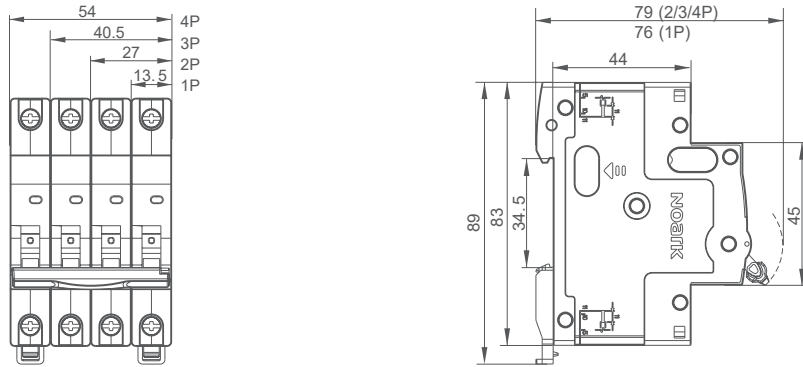

Wiring diagrams

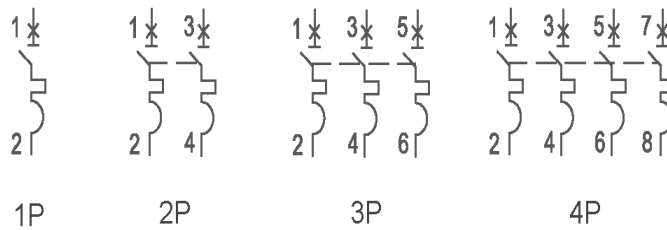

Tripping characteristics

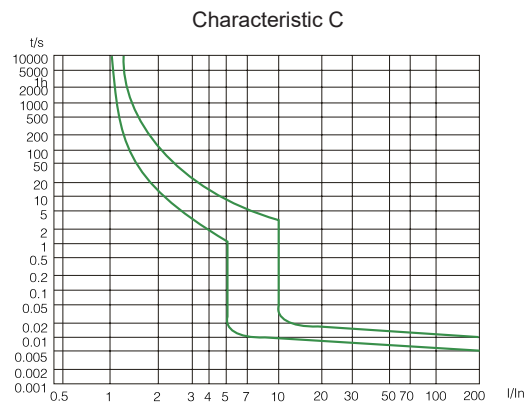
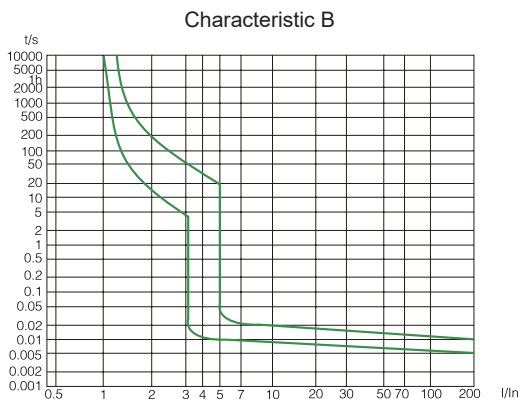

Technical Data Ex9B40J

Slim Miniature Circuit Breakers, 6 kA

Dependence of Tripping Characteristics on Ambient Temperature

T [°C]	I _n (T) [A]										
	1A	2A	3A	4A	6A	10A	16A	20A	25A	32A	40A
-35	1.3	2.6	3.9	5.2	7.8	13.2	21.12	26.4	33	42.24	52.8
-20	1.24	2.48	3.72	4.96	7.44	12.5	20	25	31.25	40	50
-10	1.19	2.38	3.57	4.76	7.14	12	19.2	24	30	38.4	48
0	1.15	2.3	3.45	4.6	6.9	11.5	18.4	23	28.75	36.8	46
10	1.08	2.16	3.24	4.32	6.48	10.8	17.28	21.6	27	34.56	43.2
20	1.05	2.1	3.15	4.2	6.3	10.5	16.8	21	26.25	33.6	42
30	1	2	3	4	6	10	16	20	25	32	40
40	0.965	1.93	2.895	3.86	5.79	9.5	15.2	19	23.75	30.4	38
50	0.93	1.86	2.79	3.72	5.58	9	14.4	18	22.5	28.8	36
60	0.89	1.78	2.67	3.56	5.34	8.5	13.6	17	21.25	27.2	34
70	0.85	1.7	2.55	3.4	5.1	8	12.8	16	20	25.6	32

Power loss per pole

I _n [A]	1	2	3	4	6	10	16	20	25	32	40
P [W]	1.9	2.2	1.9	2.2	2.4	1.6	2.2	1.8	2.3	3.3	3.4